

DAVEY WATER PRODUCTS LIMITED WARRANTY

1. The guarantee period commences on the date of original purchase of the equipment. Evidence of this date of original purchase must be provided when claiming repairs under guarantee. It is recommended you retain all receipts in a safe place.
2. Davey products are warranted to the original user only to be free of defects in material and workmanship for a period of 12 months from date of installation, but no more than 24 months from date of manufacture. Davey's liability under this warranty shall be limited to repairing or replacing at Davey's option, without charge, FOB Davey's distribution center or authorized service agent. Davey will not be liable for any costs of removal, installation, transport or any other charges that may arise in connection with the warranty claim.
3. This guarantee is subject to due compliance by the original purchaser with all directions and conditions set out in the Installation and Operating Instructions. Failure to comply with these Instructions, damage or breakdown caused by fair wear and tear, negligence, misuse, incorrect installation, inappropriate chemicals or additives in the water, inadequate protection against freezing, rain or other adverse weather conditions, corrosive or abrasive water, lightning or high voltage spikes or through unauthorized persons attempting repairs are not covered under guarantee. The product must only be connected to the voltage shown on the nameplate.
4. Davey shall not be liable for any loss of profits or any consequential, indirect or special loss, damage or injury of any kind whatsoever arising directly or indirectly from the product or any defect, and the purchaser shall indemnify Davey against any claim by any other person whatsoever in respect of any such loss, damage or injury.
5. Some states do not allow the exclusion or limitation of incidental or consequential damages or limitations on how long an implied warranty lasts, so the above limitations or exclusions may not apply to you. The warranty gives you specific legal rights and you may also have other rights which vary from state to state.
6. This guarantee applies to all states and territories of United States of America and Canada only.

© Davey and Torrium are registered trademarks of Davey Water Products Pty Ltd.
© Davey Water Products Pty Ltd 2007



Installation and Operating Instructions for Davey BT Series Pressure Booster Systems with

DAVEY
Torrium



Davey Water Products Pty Ltd

Member of the GUD Group
ABN 18 066 327 517

Offices

Melbourne • Sydney • Brisbane • Adelaide • Perth • Townsville
New Zealand • Germany

U.S.A. - Davey Pumps Inc.

1005N. Commons Drive, Aurora, Illinois 60504
Ph: +1 630 898 6976 Fax: +1 630 851 7744
Website: daveyusa.com
E-mail: sales@daveyusa.com

P/N 401341-3 supersedes P/N 401341-2



NOTE: Prior to installation remove the red transport plugs & associated seals from the suction and/or discharge ports.



WARNING : The Torrium® controller, pump and associated pipework operate under pressure. Under no circumstances should the Torrium® controller, pump or associated pipework be disassembled unless the internal pressure of the unit has been relieved. Failure to observe this warning will expose persons to the possibility of personal injury and may also result in damage to the pump, pipework or other property.



WARNING: Failure to follow these instructions and comply with all applicable codes may cause serious bodily injury and/or property damage.

Please pass these instructions on to the operator of this equipment.



Prior to using this pump you must ensure that:

- The pump is installed in a safe and dry environment
- The pump enclosure has adequate drainage in the event of leakage
- Any transport plugs are removed
- The pipe-work is correctly sealed and supported
- The pump is primed correctly
- The power supply is correctly connected
- All steps have been taken for safe operation

Appropriate details for all of these items are contained in the following Installation and Operating Instructions. Read these in their entirety before switching on this pump. If you are uncertain as to any of these Installation and Operating Instructions please contact your Davey dealer or the Davey office as listed on the back of this document.

Congratulations on your purchase of a high quality, Davey pressure booster system. All components have been designed and manufactured to give trouble free, reliable operation.

Your new pressure booster system incorporates 'Torrium®', electronic flow controller – a Davey designed unit that enables the use of a highly efficient pump design and offers the following benefits:-

1. Enables the pump to deliver a constant flow of water particularly at low flow rates – reducing the inconvenience of pressure variation in showers, etc.
2. Provides automatic “cut-out” protection should the pump run out of water or overheat*, should the pump fail to start due to low voltage or a blockage in the pump.
3. Provides warning indications for critical and noncritical system faults.
4. Has adaptive pressure cut-in which allows the pump to start at approximately 80% of the maximum pressure at last shut-down. This allows the controller to accommodate varying inlet pressures and pump performance.
5. Automatic retry functions in the event of a critical system fault.

* Motor overload / overheat protection included. Motor has its own overload / overheat protection.



Before installing your new pump, please read all instructions carefully as failures caused by incorrect installation or operation are not covered by the guarantee. Your Davey pressure booster system is designed to handle clean water. The system should not be used for any other purpose without specific referral to Davey. The use of the system to pump flammable, corrosive and other materials of a hazardous nature is specifically excluded.

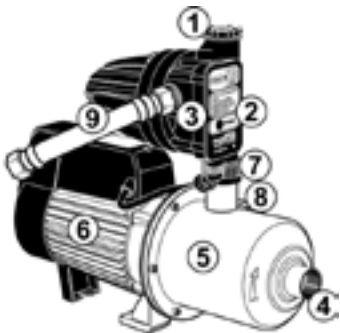

1. Torrium® Priming Plug
2. Torrium® Control Module
3. Discharge Outlet
4. Suction Inlet
5. Pump Body
6. Motor
7. Rotary Coupling
8. Priming Plug (pump)
9. Stainless Steel Braided Hose (1”F x 1”F)

Preparing Your System

On removing your pressure booster system from its carton you will need to position the Torrium® control module on top of the pump. Once in position on top of the pump hand tighten the locking nut. The Torrium® unit is capable of 360° rotation to enable the most convenient positioning of the discharge piping. This can be done without the need to loosen the locking nut on the rotary coupling.

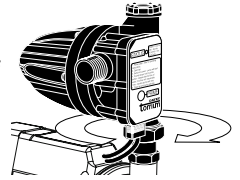

Only connect the discharge pipework to the discharge port. The priming port is not a discharge port.

Rotary Coupling Installation

Your Davey Water Pressure Booster system is equipped with the convenience of the Davey Rotary Coupling. This coupling allows the pump controller to be fitted simply and easily to the pump discharge.

The rotary coupling is already fitted to the pump discharge port. The controller adaptor nut is able to rotate independent of the pump adaptor nipple and thus the complete pump, this allows it to be tightened onto the pump controller inlet. – see illustration below. Hand tighten only the controller adaptor nut to ensure a firm connection to your controller. The oring on the base of the controller will ensure a leak-proof seal between the rotary coupling and the controller.

The ability to rotate the adaptor nut also means that the complete controller, once fitted to the rotary coupling, can be rotated a full 360 degrees in the horizontal plane, without causing the coupling to unscrew from the pump outlet.

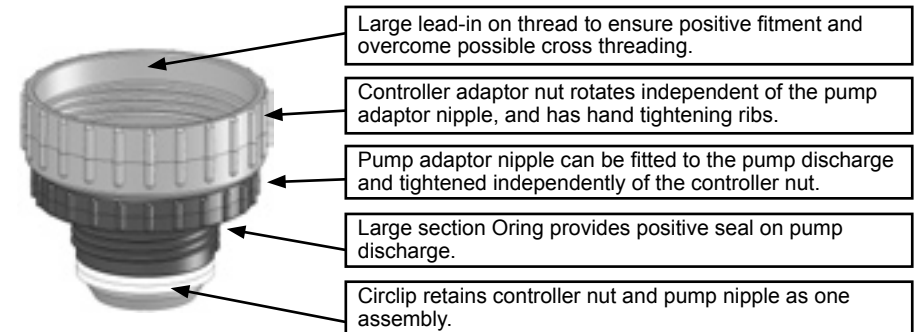

Firmly hand tighten. Fit the 1" stainless steel flexible hose to the discharge using the black rubber gaskets (one each end) included.

Choosing a Site

Choose a site with a firm base and as close to the water source as possible with correct power supply. Make sure your pressure booster system is always connected to an adequate, reliable source of clean water.

Housing your Davey System

To protect your pressure booster system from the weather, make sure the pump house is both water proof, frost free and has adequate ventilation. The pump should be horizontally mounted on a firm base allowing for drainage, to avoid damage to flooring etc., that over time may occur from leaking pipe joints or pump seals. Do not mount the pump vertically. Never place flammable materials on or near your pump.

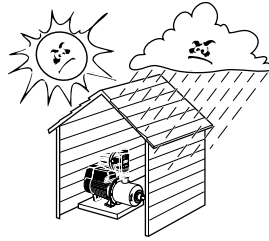

WARNING: Some insects, such as small ants, find electrical devices attractive for various reasons. If your pump enclosure is susceptible to insect infestation you should implement a suitable pest control plan.

Electrical Connection



The electrical connections and checks must be made by a qualified electrician and comply with applicable local standards. Poor installation or poor power supply may even result in electrical fires!



The Davey Torrium® fitted to this pump has a status indicator light mounted on its front panel. This light will be illuminated whenever the Torrium® senses that there is electrical power available. The light will only work when unit is connected to the correct electrical supply.



Connect power cord to power supply designated on pump label. Do not use long extension cords as they cause substantial voltage drop, poor pump performance and may cause motor overload.

BT14-30, BT20-30 and BT14-45 models are 115 volt 60Hz models, fitted with NEMA 5-15P plugs intended for direct connection to a three pin wall socket. BT20-40 models are 230 volt 60Hz only and are fitted with NEMA 6-15P plugs intended for direct connection to a 6-15R three pin wall socket. The color codes are: Green = Ground/Earth, Black = Hot, Active or L1, White = Neutral or L2.

Ensure that the circuit including the breakers on the power supply have sufficient capacity to accommodate pump starting amperage. Davey recommend a minimum circuit capacity of 20 amps for 115 volt models and 10 amps for 230 volt models.



Power connections and wiring must be carried out by an authorized electrician.



All wiring must conform to National (NEC), CSA, state, provincial, and local codes. Power supply voltage, phase and controls must match motor.



This pump is not to be used by children or infirm persons and must not be used as a toy by children.



NOTE: For protection, the Davey® pump motor is fitted with an automatic “over temperature” cut-out. Constant tripping of this overload device indicates a problem e.g. low voltage at pump, excessive temperature (above 115°F) in pump enclosure.



NOTE: To protect the pump, the Torrium fitted to your pump has a secondary over temperature function built-in. This function automatically stops the pump should the water in the pump reach 170°F. The pump will automatically restart once the water temperature drops below 170°F.



Motor normally operates at high temperature and may be too hot to touch. Before handling pump or motor, stop motor and allow it to cool.



WARNING: When servicing or attending pump, always ensure power is switched off and lead unplugged. Electrical connections should be serviced only by qualified persons.



Care should also be taken when servicing or disassembling pump to avoid possible injury from hot pressurized water. Unplug pump, relieve pressure by opening a tap on the discharge side of the pump and allow any hot water in the pump to cool before attempting to dismantle.



During servicing, use only approved, non-petrochemical based oring and gasket lubrication. If unsure, consult your Davey dealer for advice.



WARNING: Do not use hydrocarbon based or hydrocarbon propelled sprays around the electrical components of this pump.

After Sales Service

For professional after sales service or repair contact your Davey dealer. For assistance in locating your nearest dealer contact the Davey Service Center on 1-866-328-7867 or go to :-



d) MOTOR STOPS - STATUS INDICATOR LIGHT IS ILLUMINATED RED, FLASHING TWICE PER SEQUENCE

1. Motor "over temperature" cut-out tripped. Consult Davey dealer.
2. Motor not free to turn - e.g. a jammed impeller. Consult Davey dealer.
3. Prime button has been held in for too long. Release prime button and switch off power for 1 minute to allow unit to reset.

e) PUMP WILL NOT STOP

1. Water leaks on discharge side of pump.

f) PUMP WILL OPERATE NORMALLY INITIALLY BUT WILL NOT RESTART ON WATER DEMAND - STATUS INDICATOR LIGHT NOT ILLUMINATED

1. Power supply problem - see c) 1.

g) PUMP WILL OPERATE NORMALLY INITIALLY BUT WILL NOT RESTART ON WATER DEMAND - STATUS INDICATOR LIGHT IS ILLUMINATED RED CONSTANT

1. Suction air leak - pump has partially lost prime.
2. Blocked impellers or suction.
3. Discharge valve closed - open valve.

h) PUMP HAS OPERATED NORMALLY FOR SOME TIME, BUT NOW WILL NOT RESTART OR THE PRESSURE DROPS TO A LOWER POINT BEFORE THE PUMP STARTS – STATUS INDICATOR LIGHT IS ILLUMINATED WITH THREE FLASHES PER SEQUENCE

1. Your Torrium® has detected a slow leak and has dropped the cut-in pressure to a lower cut-in pressure to help reduce the pump cycling. Correct the leak, and your Torrium will return to normal operation automatically or cycle power for immediate return to normal.



NOTE: The Torrium® controller fitted to this pump is adaptive. If your pump draws air or is subject to blockage, the Torrium adapts to its new maximum pressure. This may result in your system pressure not dropping below the new cut-in pressure and your pump not starting. Should this occur, re-prime your pump units as detailed above. Should this not prove successful, it is likely you have a blockage in the pump. You should contact your Davey dealer for assistance.

i) PUMP HAS STOPPED OPERATING – STATUS INDICATOR LIGHT IS ILLUMINATED RED FLASHING THREE TIMES PER SEQUENCE.

1. Your Torrium® has detected high water temperature in the pump. Once the water has cooled the Torrium will automatically restart the pump.

j) PUMP IS OPERATING NORMALLY, BUT THE STATUS INDICATOR LIGHT IS ILLUMINATED FLASHING TWICE PER SEQUENCES – RED FLASHES WHILE IN STANDBY OR AMBER FLASHES WITH CONSTANT GREEN WHILE PUMP RUNNING

1. Your Torrium® has detected low voltage. The low voltage may result in a small pump performance shortfall. Once the voltage has returned to normal the status indicator will return to normal.

Status Indicator

The Torrium® has a status indicator light on the front panel. This light will enable you to understand what your pump is doing.

| Condition | Indicator readout | Pump operation | Restart / Reset Method |
|---|------------------------|---|--|
| Standby mode | Red light | Standby | Pressure drop |
| Running | Green light | Running | N/A |
| Cistern fill | Green light | Running - 2 minutes minimum run time | Auto, push "Prime" button or cycle power off / on |
| Loss of Prime | Red light single flash | Stops, auto-retry & "water return" activated | Push "Prime" button or cycle power off / on |
| Locked rotor or 'Prime' button held in too long | Red light double flash | Stops | See Trouble shooting guide |
| Undervoltage | Red light double flash | Normal operation | Wait till the voltage is > 90 volts for 110-120 volt models or 180 volt for 220-230 volt models or push "Prime" button or cycle power off/on |
| Water over temperature | Red light triple flash | Stops | Wait till water temp < 140°F |
| Slow leak | Red light triple flash | Normal operation with reduced cut-in pressure | Auto-reset or push "Prime" button or cycle power off / on |

Both the Red & Green Indicators are shown in the same window. It is possible for the pump to be running (ie. Green indicator) and for a Red flash sequence to happen at the same time. In that case the Red flash will show as a Yellow or Amber flash.



Only one fault condition will be indicated at once.



NOTE: Torrium® controller stops pump when flow is below 1/2 gpm.

Cistern Fill Mode

When your new BT Series pressure booster system is used to fill toilet cisterns or troughs, a special feature of the Torrium® controller may be activated. This special feature is activated when the controller detects three quick stop start sequences in a short period. When activated the status indicator will glow "Red", and the pump will run on for two minutes before shutting down. This allows the cistern to be filled with the minimum number of pump cycles.

Auto-retry and Water Return Modes

Should your Torrium® detect a loss of prime, after stopping the pump, it will wait five minutes before activating Auto-retry and Water Return modes. Auto-retry automatically starts the pump to see if the pump is now primed. It does this after 5 mins, 30 mins, 1 hr, 2 hrs, 8 hrs, 16 hrs and 32 hrs. Water return mode will restart the pump automatically if the Torrium® detects water flow through it.



NOTE: If multiple errors are present, the highest priority error (least number of flashes) is indicated. Any previous fault code is lost until it recurs.

Electrical Power Surge Protection

An electrical power surge or spike can travel on the supply lines and cause serious damage to your electrical equipment. The Torrium® fitted to this pump has a metal oxide varistor (MOV) fitted to help protect it's circuit. This MOV is a "sacrificial" device, meaning that effectively it is gradually damaged every time it takes a surge. The MOV is not a lightning arrestor and may not protect the Torrium® if lightning or a very powerful surge hits the pump unit.

If the installation is subject to electrical power surges or lightning we strongly recommend the use of suitable additional surge protection devices on ALL electrical equipment.

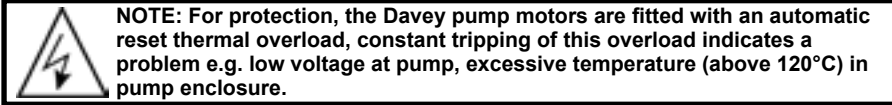

Always disconnect and lockout all electrical power when installing or working on pumps, motor or switches. Insure the power supply breaker is off or the disconnect (where used) is off.

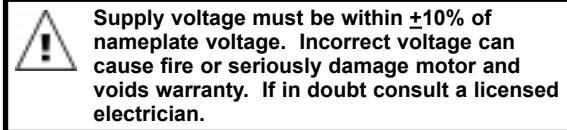
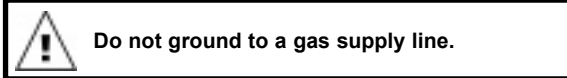
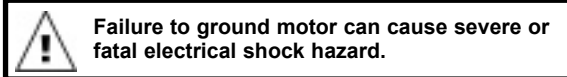
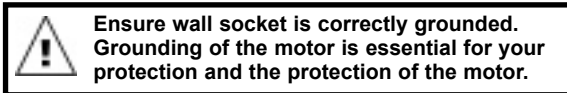

Pipe Connections

For best performance use pipes at least the same diameter as the pump's inlet and delivery outlet openings. Larger diameter pipe may be used to minimize resistance to flow when pumping longer distances. When pump is installed with incoming pressure (eg. boosting municipal supply) smaller inlet and outlet pipes may be adequate.

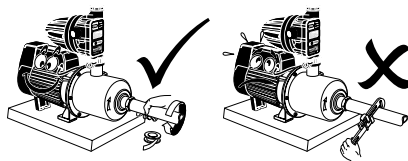

Maintenance (if pressure tank is fitted)

The only regular attention your new pressure system may require will be if you have used an additional pressure tank. You will need to check the pressure tank's air charge every 6 months. This can be checked at the air valve with a tire gauge (see Extra Draw Off Capacity section on page 6).

To check air pressure in tank:

1. Switch off pump.
2. Open outlet nearest to pump to release water pressure.
3. Charge tank to required pressure using air pump and check with tire gauge.
4. Switch on.
5. Close outlet.

Where freezing may be a problem, all pipework should be buried and/or insulated (lagged) to prevent this happening. Your Davey pump should be housed in an enclosure which does not experience temperatures below freezing (32°F).

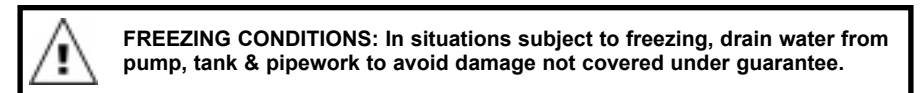

Trouble Shooting Check List

- a) **PUMP HAS STOPPED OR MOTOR RUNS FOR SHORT PERIOD ONLY WHEN SWITCHED ON OR PRIME BUTTON PUSHED, BUT DOES NOT PUMP - STATUS INDICATOR LIGHT ILLUMINATED RED FLASHING ONCE PER SEQUENCE**
 1. Suction line and pump body not filled with water.
 2. Air leaks in suction lines or suction pipe not under water.
 3. Air trapped in suction lines (also possible with flooded suction due to uneven rise in piping; eliminate humps and hollows).
 4. No water at source or water level too low.
 5. Valve on suction lines closed. Open valve & pump will restart automatically or press "Prime" button.
- b) **PUMP SWITCHES ON AND OFF FREQUENTLY (CYCLING)**
 1. Cycling may occasionally be caused by float valves filling tanks - see "Cistern Fill Mode".
 2. Leaking taps, float valves etc. check plumbing.
 3. Leaking check valve/foot valve.
 4. Discharge plumbing has been connected to the priming port.
- c) **MOTOR DOESN'T START WHEN SWITCHED ON - STATUS INDICATOR LIGHT NOT ILLUMINATED**
 1. Power not connected or no power available from supply outlet.

! Abrasive Materials
The pumping of abrasive materials will cause damage to the pressure system which will then not be covered by the guarantee.

For Automatic Pressure Pumps Installed with a Mains Pressure Hot Water System

To protect your system from damage caused by back pressure from hot water systems, you should always have installed on the hot water inlet an approved non-return valve. In some cases an expansion tank may be required. Please consult an HVAC specialist.

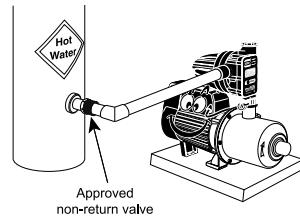

! NOTE: Always ensure hot water systems are installed in compliance with manufacturers recommendations and in accordance with all local regulations.

Priming and Operation

The Torrium® module fitted to your BT Series system is provided with a push button "Prime" button. This button is used during initial priming of the pump and also acts as a reset button if the Torrium® switches out in pump protection mode.

1. Remove priming plug and fill casing and suction line (on flooded suction, simply open gate valve to pump). When full, replace priming plug.

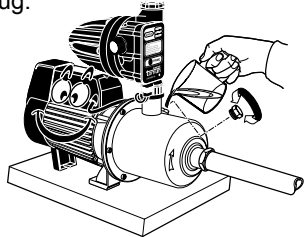

2. Ensure outlet nearest to pump is open.



4. Switch on power - The status indicator light will be illuminated green and the pump will run. A full flow of water should be discharged from the open tap.

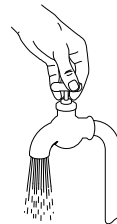

5. If the pump stops with the tap open see troubleshooting checklist.

6. Close the open outlet or tap and the pump should stop after a few seconds (the status indicator light should be illuminated red (constant). If not, consult the troubleshooting checklist.

To Reset if Pump switches out in Pump Protection Mode

3. Ensure all valves in suction line are open.

1. Make sure pump is primed.
2. Open tap, push prime button.
3. Close tap and pump will stop.

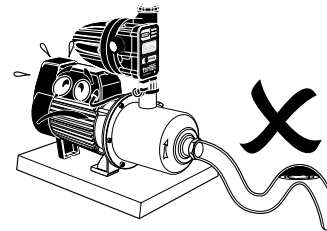

Use 1" braided hose supplied to connect Torrium® outlet to discharge pipework. Ensure the gaskets are correctly sealed inside the nut at each end of the hose. Use unions at pipe connections to enable easy removal and servicing. Use sufficient tape to ensure airtight seal and hand tighten only. To prevent strain on pump threads always support heavy inlet and outlet pipes. If there is a likelihood the water supply may contain solid particles such as pieces of plant or vegetable matter, a filter should be installed before the pump to avoid blocking of water ways. Ensure filter is cleaned regularly. Lay suction pipe at a constant gradient to avoid air pockets which may reduce pump efficiency.

! NOTE: Suction leaks are the largest cause of poor pump performance and are difficult to detect. Ensure all connections are completely sealed using thread tape only. An air leak on the suction may not drip water!

Connection to your Water Source FLOODED SUCTION - FROM CISTERN OR STORAGE TANK

Installations with flooded suction require a gate valve so water supply can be turned off for pump removal and servicing.

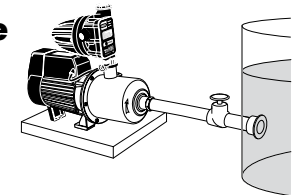

FLOODED SUCTION - FROM MUNICIPAL WATER SUPPLY OR WELL PUMP Connection of Municipal Water Supply to either Suction or Discharge of Pumps & Pressure Systems

Most Water Supply Authorities have strict regulations regarding direct connection of pumps to municipal water supplies. In some cases an isolating tank is required between mains supply and pump. Directly applied municipal pressure can exceed pump operating pressure and damage pump (see table below).

| Models | Maximum Inlet Pressure |
|-------------------|------------------------|
| BT14-30 & BT20-30 | 60 psi |
| BT14-45 | 50 psi |
| BT20-40 | 20 psi |

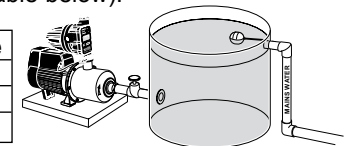

! NOTE: The above pressure limits also apply to well pump boosting.

A pressure reducing valve is required on the suction side of the pump when the incoming pressure is greater than shown on the table above. In some areas, local codes restrict maximum allowable home pressures, and in those cases the pressure reducing valve will need to be set to lower pressures. The chart below shows the applicable settings for the pressure reducing valve.

| Local code limits for home pressure | Pressure reducing valve setting (psi) | | | |
|-------------------------------------|---------------------------------------|---------|---------|---------|
| | BT14-30 | BT20-30 | BT14-45 | BT20-40 |
| No limit | 60psi | 50psi | 50psi | 20psi |
| 80psi | 40psi | 30psi | 30psi | N/A |
| 70psi | 30psi | 20psi | 20psi | N/A |

Davey Products Pty Ltd can not accept responsibility for loss or damage resulting from incorrect or unauthorised installations.

Municipal Water Supply Application

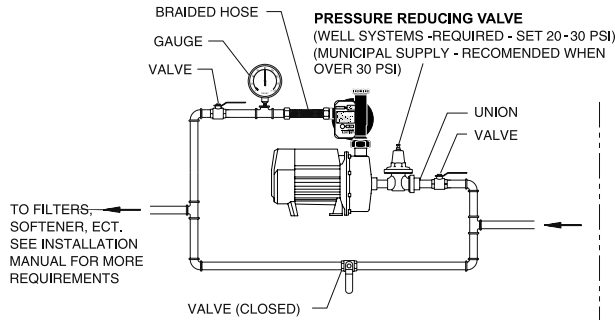

Do not exceed a total system pressure of 116psi

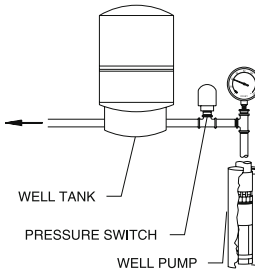
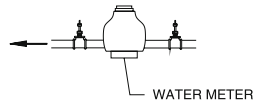

Well Pump Application



Abrasive Materials

The pumping of abrasive materials will cause damage to the pressure system which will then not be covered by the guarantee.

BELOW GROUND WATER SOURCES

Whenever the installation position of the pump is higher than 3ft above the lowest water level, a foot valve must be used on the end of the suction pipe as illustrated in (A). Ensure that the foot valve is at least 1 1/2 feet below minimum water level.

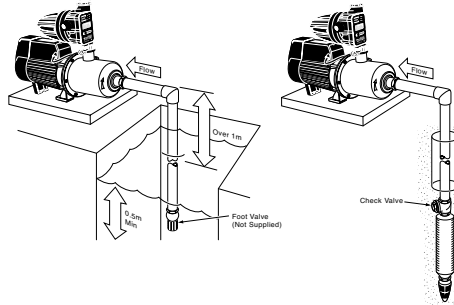

(DRIVEN) POINT INSTALLATIONS

When a Multistage Pressure Boosting System is installed on a (driven or well) point, a check valve must be fitted immediately on top of the driven point itself, as shown in (B). **DO NOT INSTALL THE CHECK VALVE AT THE PUMP OR AT THE TOP OF THE WELL. DO NOT RUN THE PUMP WITHOUT WATER. NOTE: Be certain to select the driven point to suit the well conditions and regulate the flow rate from the pump accordingly.**

| DRIVEN SIZE | MESH | APPROX. MAX. CAPACITY OF DRIVEN POINT |
|-------------|------|---------------------------------------|
| 1 1/4" | 60 | 200 - 350 gal/hr |
| 1 1/2" | 60 | 350 - 600 gal/hr |
| 2" | 60 | 600 - 1150 gal/hr |



Driven point flow capacities vary considerably. Check with the supplier to ensure the pump and spear point are correctly matched.

Extra Draw-off Capacity

The Torrium® controller has an in-built accumulator which will accommodate small leaks. In some applications it may be appropriate to install additional accumulator (Supercell pressure tank) capacity. These applications includes:

- Long suction lines (see Suction Lines / Lift)
- Low flow appliances connected to the pump, such as evaporative air conditioners, slow filling toilet cisterns.

Any additional accumulators can be installed either in place of the priming plug (see Priming & Operation section page 8) for tanks up to 5 gallons total capacity, or for larger tanks, downstream of the controller (ie. between the controller and the first outlet).

Where extra draw-off capacity is utilized the additional pressure tank should have a pre-charge of 70% of the maximum system (shut-off) pressure, including the municipal base pressure where applicable.



DO NOT USE THREAD SEALING COMPOUNDS, HEMP OR PIPE DOPE!

Where to use Check Valves and Foot Valves

The Torrium® controller fitted to BT Series has an in-built non-return (check) valve fitted. In flooded suction installations there is no need to have a suction non-return valve.

In suction lift installations a footvalve will normally be required for the pump to retain prime. Where the footvalve may occasionally leak (eg due to grit or debris being trapped under the seat), it may be appropriate to remove the Torrium® controller's in-built check valve and install an additional accumulator capacity as required.

Torrium® Check Valve Removal

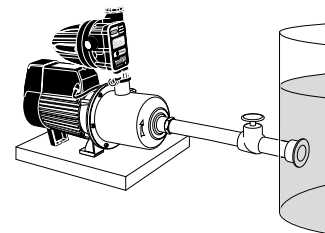
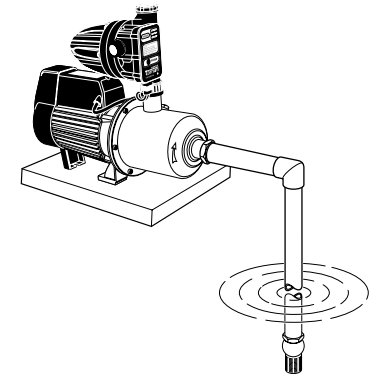
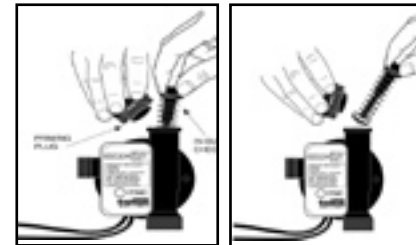

Installations with flooded suction require a gate or isolating valve so water supply can be turned off for pump removal and servicing.