



WellZone™ Pressure Controller

Single Phase 3-Wire Well Pump Control Panel

Installation and Operation Manual

Parts Included



Specifications

Input Voltage: 230 VAC, 60Hz

Operating Temperature:
14° to 122° (-10° to 50°)

Pump Ratings:

Single phase, 3-wire (4~17FLA)

Enclosure:

10 x 8 x 4 inch (25.4 x 20.3 x 10.2 cm)

NEMA 4X thermoplastic

Includes liquid tight cable strain relief fittings:

- 1 x 1/2" + 1 x 3/4" UF cable
- 1 x 1/2" round cable

Pressure Transducer:

0-150 PSI (included) 1/4" NPT Male, NSF 61 rated, 4-20mA, with 16.4 ft (5m) cable

Auxiliary Alarm Contacts:

N.O. 1 amp, 120 VAC Max

Part #	Description	3-WIRE MOTOR			RUN CAP	START CAP	CB
		HP	Volts	SFA	Mfd	Mfd	
1094602	WELLZONE 3W-050	1/2	230	4.3	15	43-53	15A
1094603	WELLZONE 3W-075	3/4	230	5.7	23	59-71	20A
1094604	WELLZONE 3W-100	1	230	7.1	23	86-103	20A
1094605	WELLZONE 3W-150	1 1/2	230	11.5	15	105-126	20A
1094606	WELLZONE 3W-200	2	230	13.2	20	105-126	25A
1094638	WELLZONE 3W-300	3	230	17.0	45	208-250	30A



WARNING!

ELECTRICAL SHOCK HAZARD
Disconnect all power sources before servicing. Failure to do so could result in serious injury or death.

This digital controller does not provide Variable Speed Pump Control or constant pressure operation. This control panel must be installed and serviced by a licensed electrician in accordance with the National Electric Code NFPA-70, state and local electrical codes. UL Type 4X enclosures are for indoor or outdoor use.

Warranty void if panel is modified.



For information regarding operation, available options, or servicing questions, please call SJE Rhombus Technical Support.

SJE Rhombus offers a five-year limited warranty. For complete terms and conditions, please visit www.sjerhombus.com.

Products returned must be cleaned, sanitized, or decontaminated as necessary prior to shipment to ensure that employees will not be exposed to health hazards in handling said material. All applicable laws and regulations shall apply.

Features

The WellZone™ 3W digital controller provides pressure control for single phase 3-wire submersible well pump applications. It uses a 0-150 PSI pressure transducer to monitor the discharge pressure and turns the pump ON and OFF according to adjustable Start and Stop setpoints. The LCD display allows for quick view of the system pressure, run status, hours run and pump cycles. The rotary button provides the user with a simple navigation method through the menu and program settings. It features built in pump protection including rapid cycling and dry run. It is preprogrammed to run the pump as the pressure drops below 40 PSI and stop as the pressure rises above 60 PSI. High & Low pressure settings are available with an auxiliary alarm relay.

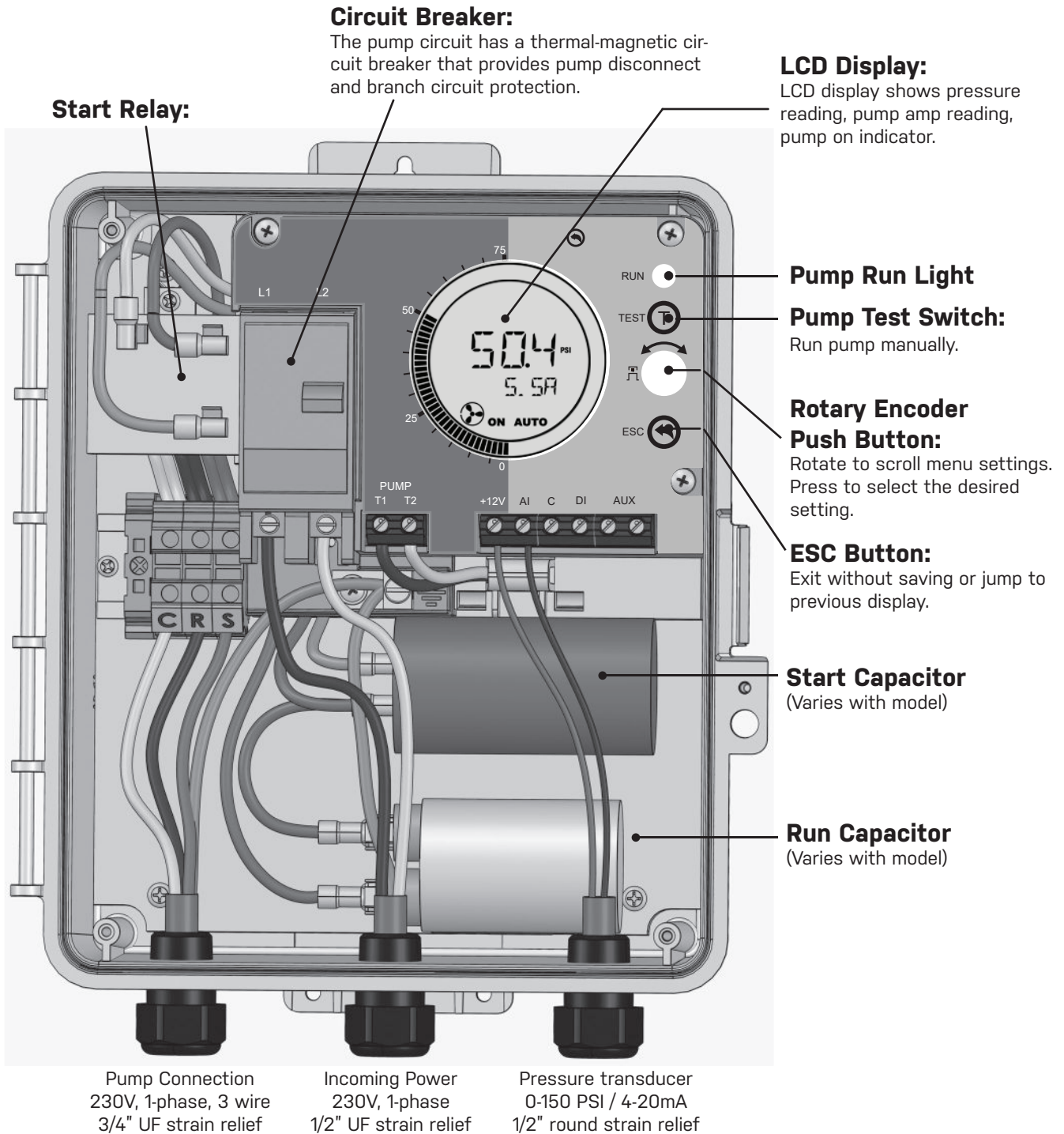

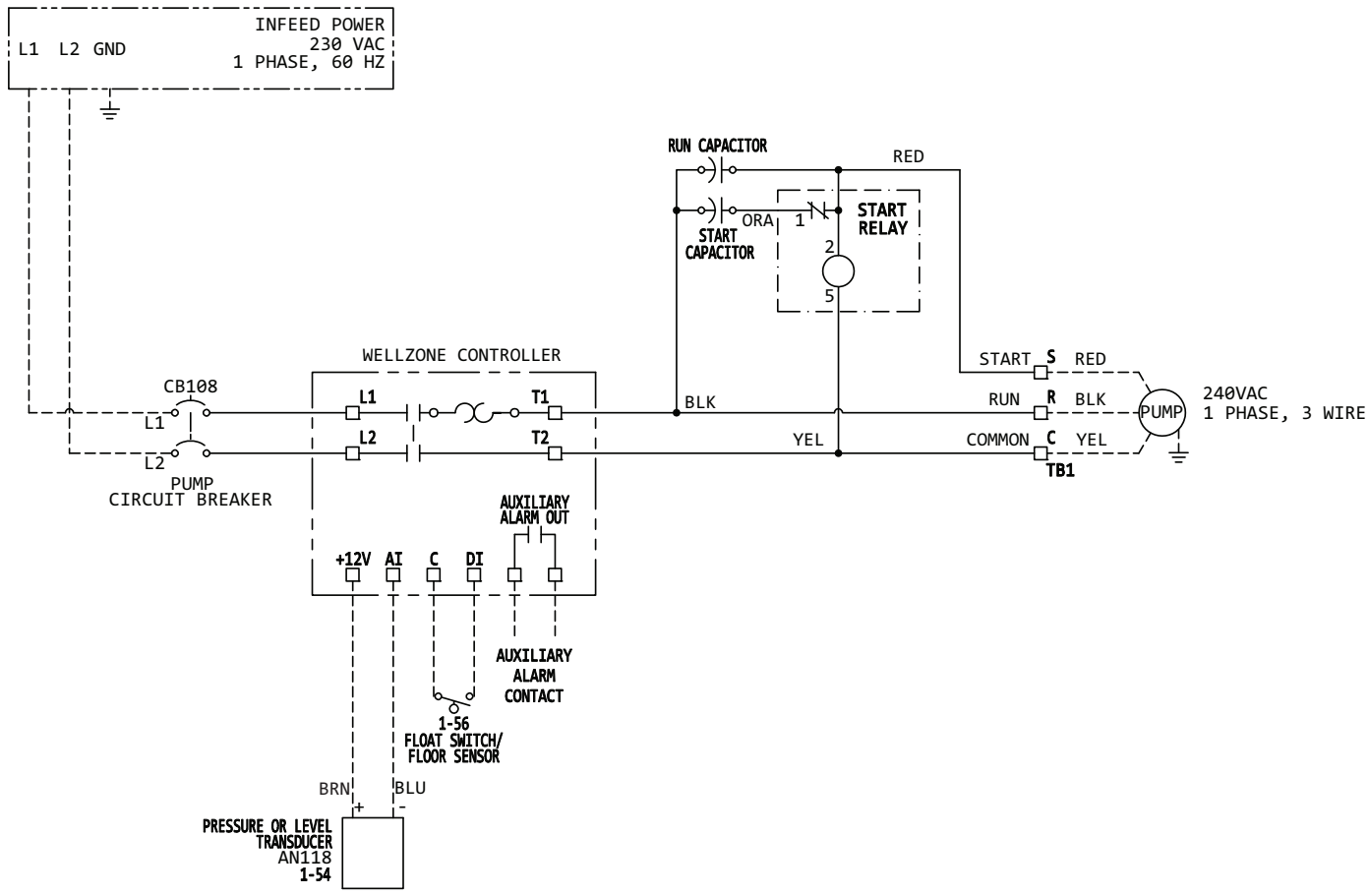

WELLZONE PANELS				
SJE P/N	DESCRIPTION	START CAPACITOR	RUN CAPACITOR	CIRCUIT BREAKER
1094602	WELLZONE 3W-050 (230V, 1/2 HP, 4.0 SFA)	40-53 MFD/250V	15 MFD/370V	15 AMP
1094603	WELLZONE 3W-075 (230V, 3/4 HP, 5.2 SFA)	59-71 MFD/250V	25 MFD/370V	20 AMP
1094604	WELLZONE 3W-0100 (230V, 1.0 HP, 6.2 SFA)	86-103 MFD/250V	25 MFD/370V	20 AMP
1094605	WELLZONE 3W-150 (230V, 1.5 HP, 11.2 SFA)	105-126 MFD/250V	15 MFD/370V	20 AMP

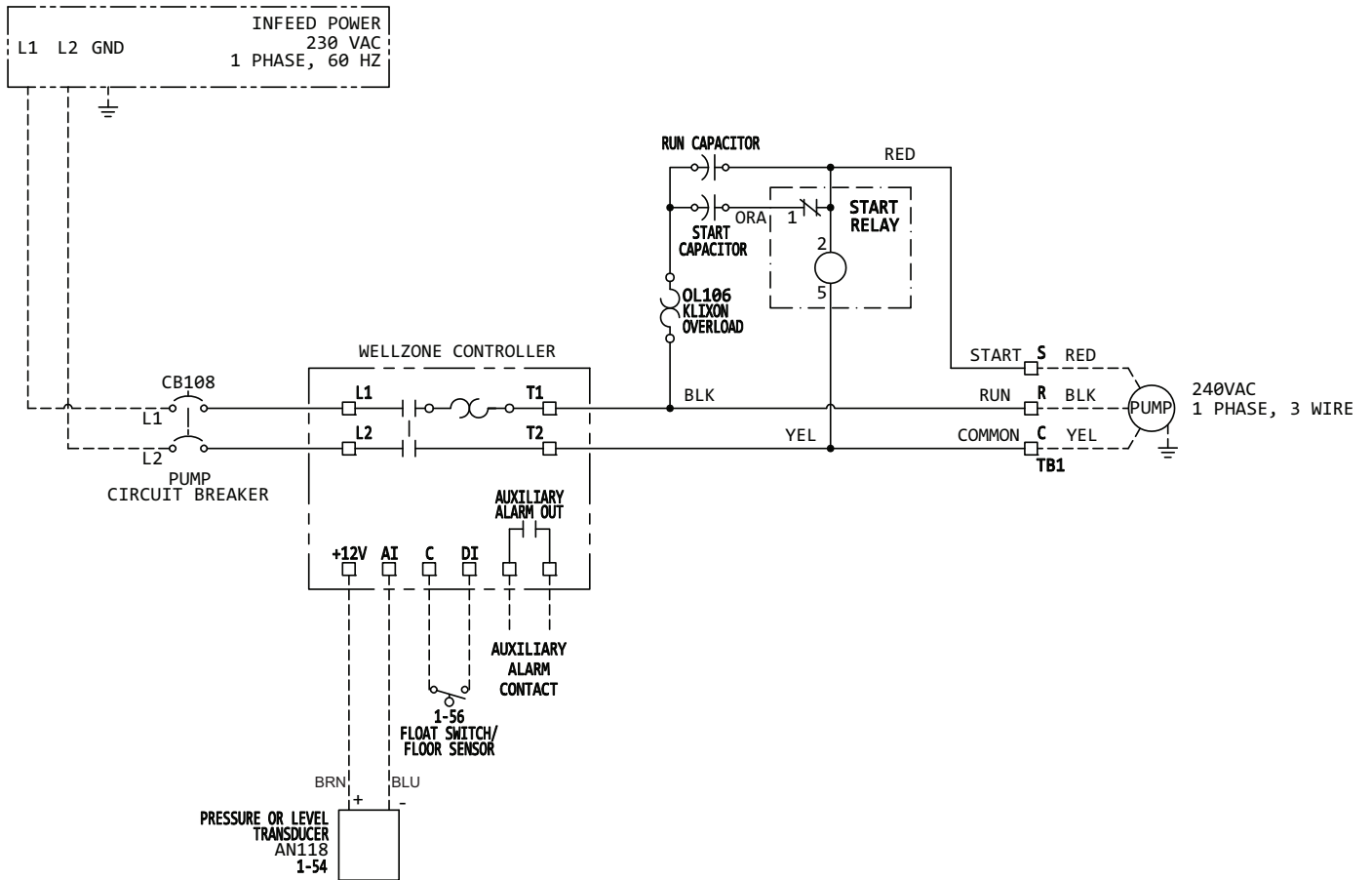

WELLZONE PANELS WITH KLIXON START OVERLOAD				
SJE P/N	DESCRIPTION	START CAPACITOR	RUN CAPACITOR	CIRCUIT BREAKER
1094606	WELLZONE 3W-200 (230V,2 HP,11.9 SFA)	105-126 MFD/250V	20 MFD/370V	25 AMP
1094638	WELLZONE 3W-300 (230V,3 HP,14.3 SFA)	208-250 MFD/250V	45 MFD/370V	30 AMP

Mounting the Control Panel

1 Drill and fasten top of the enclosure using appropriate anchor.

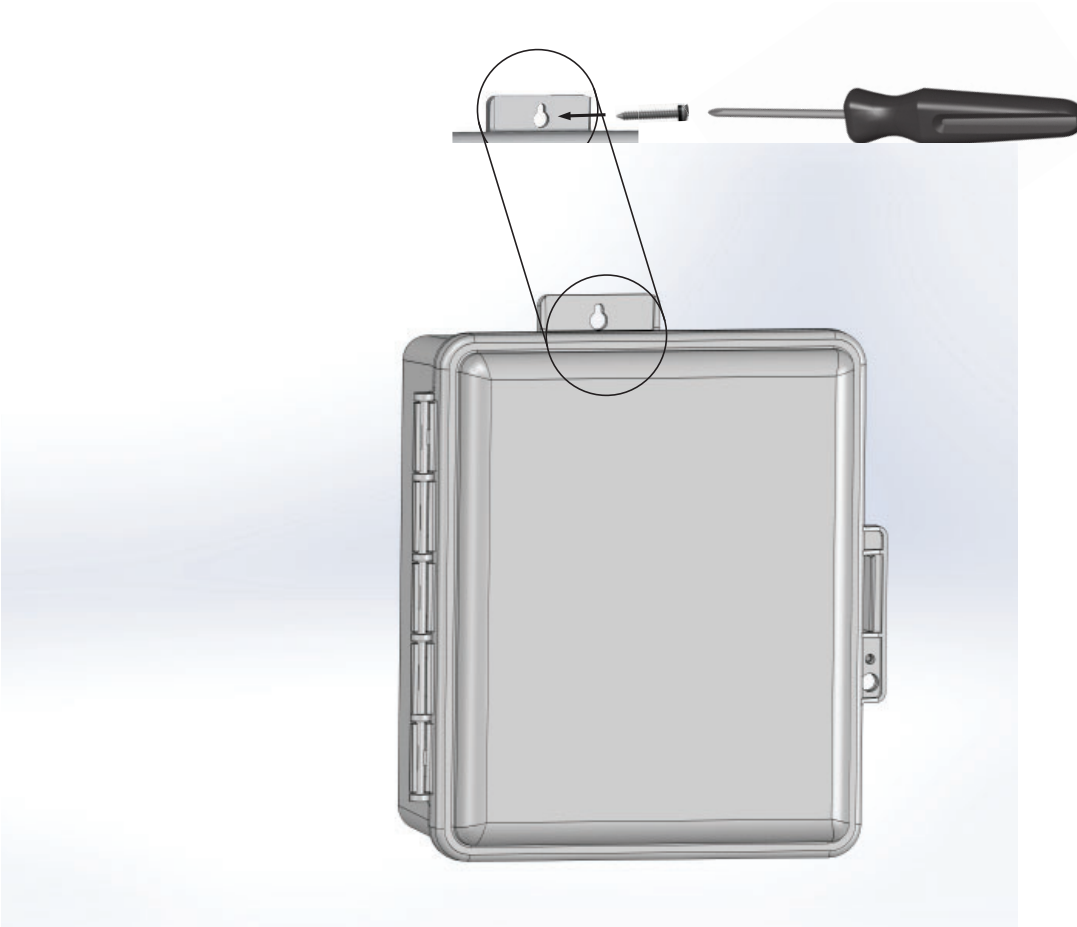

2 Drill and fasten bottom of the enclosure using appropriate anchors.

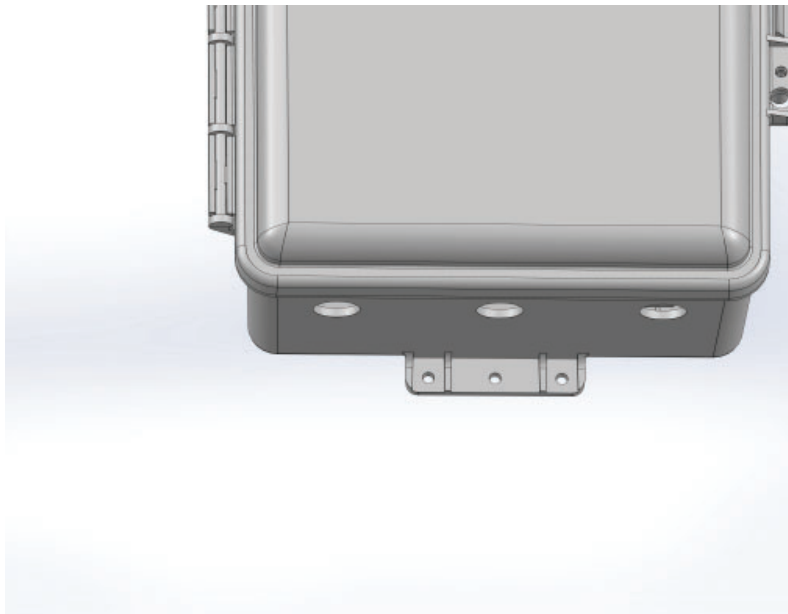

Wiring the Control Panel

⚠ CAUTION!

Disconnect all power to the control panel before wiring.

Ensure that the incoming supply power voltage is the same as the rating of the pump motor being installed. Ensure that the rated Amps of the motor does not exceed the rating of the control panel. Ensure the HP rating and Capacitor values of the control panel are correct for the pump used.

- 1 Connect the following wires to the proper terminal positions:
 - Incoming power to the circuit breaker
 - Motor/Pump power to Motor
 - Pressure transducer

See wiring label on inside the control panel for details.
- 2 Verify correct operation of control panel after the installation is complete.

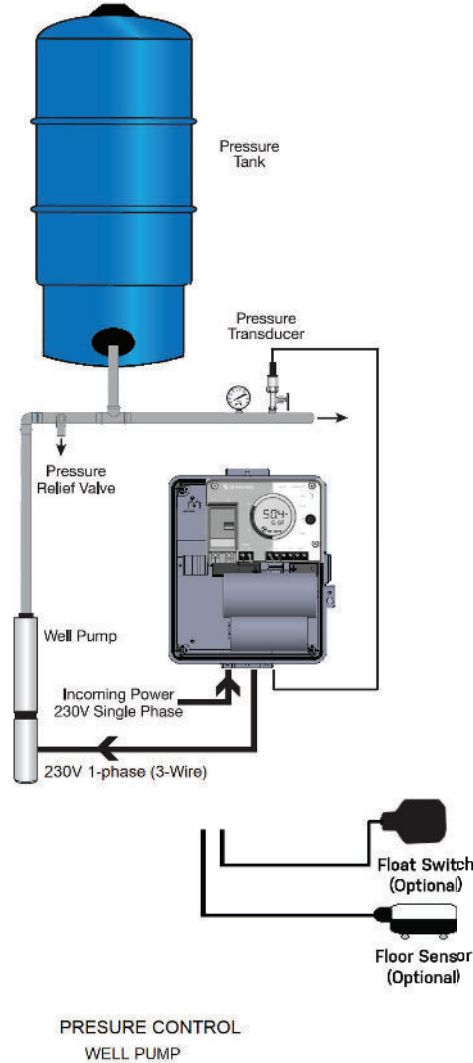

- 3 Maximum motor cable lengths.

Motor			Feet - Motor Cable (75C) ¹			
Vac	HP	Amps ²	14 AWG	12 AWG	10 AWG	8 AWG
230V	1/2HP	4.3	400	650	1000	1600
	3/4HP	5.7	300	450	750	1200
	1.0HP	7.10	250	400	600	1000
	1.5HP	11.5	175	300	450	750
	2.0HP	13.2	150	250	400	600
	3.0HP	17	120	200	300	450

¹ Cable length is measured from the motor to the main panelboard (Service Entrance)

75C Insulation - AWG Copper Wire only. Do not use aluminum conductors.

Use with 2-wire motor only with internal thermal protection.

² Typical S.F.A. (Service Factor Amps). Check motor nameplate for actual data.

Operation Guide - PRESSURE CONTROL

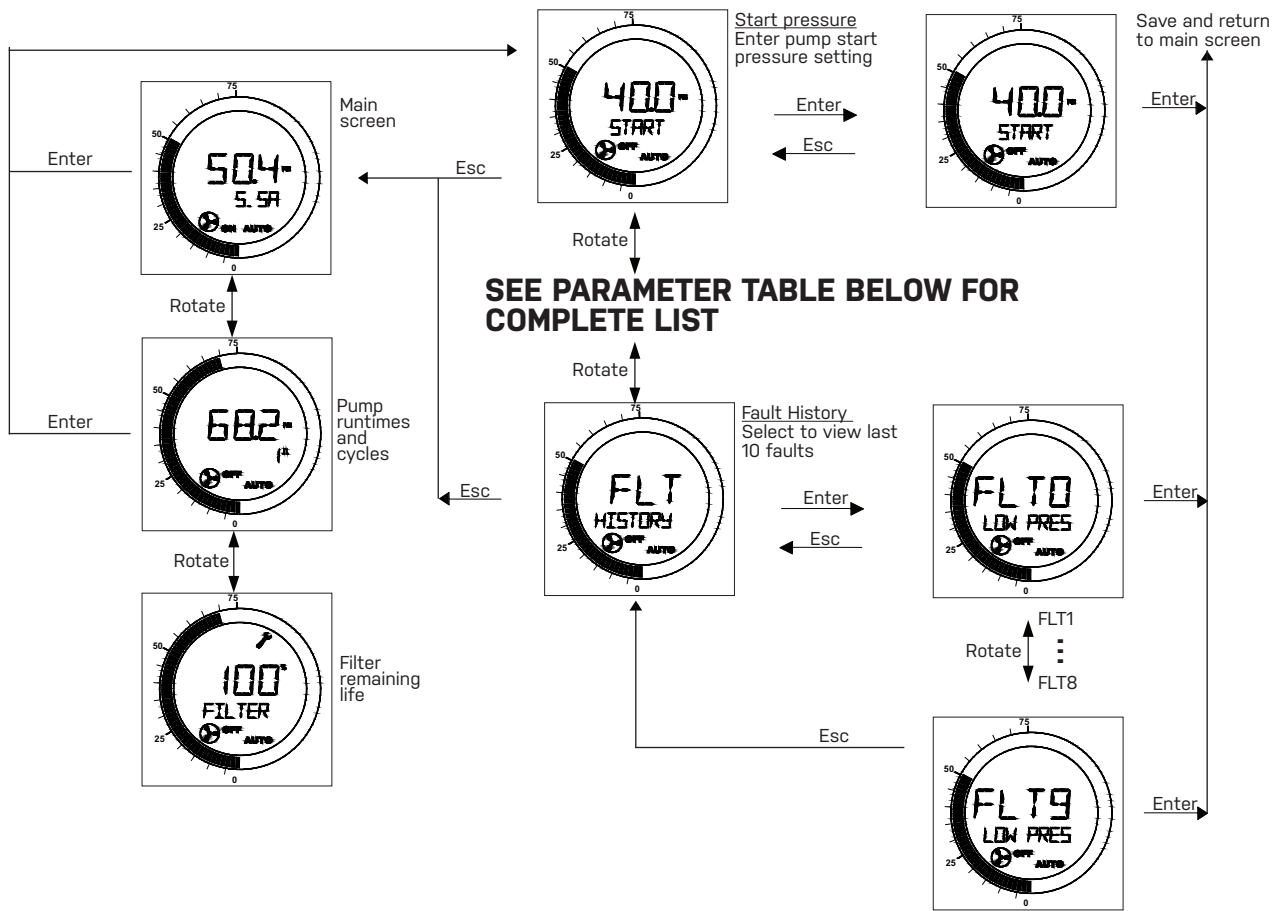

Notes :

- A. If there is no operation for 20 sec, the display will return to the main screen.
- B. The service function is used for alerting the user when it is time to change a filter or to service the equipment after the accumulated run time is reached.

The icon  will flash on main screen when the timer is done (Filter at 0%).

Push and hold ESC button 4 seconds to reset the filter or service time.

Pressure transducer = 0-150 psi

Digital input = Floor sensor (stop pump) or low level float (stop pump)

PARAMETER	Description	Default	Range Min	Range Max	Unit	Function
START	Start Pressure	40.0	1.0	140.0	PSI	The pump will RUN when the pressure drops below the "START" pressure value and continue to RUN until the pressure rises above the "STOP" value. Set START<STOP. The "STOP" value should be at least 10 PSI over the "START" value.
STOP	Stop Pressure	60.0	10.0	150.0	PSI	The pump will RUN when the pressure drop below the "START" pressure value and continue to RUN until the pressure rises above the "STOP" value.
HIGH	High Pressure	70.0	10.0	150.0	PSI	High Pressure alarm. The pump will stop if the pressure rises above this value
LOW	Low Pressure	20.0	0.0	150.0	PSI	Low Pressure alarm. If the pressure drop below this value, the "LOW TMR" timer will start. The pump will stop when the timer is done and a "LOW PRESS" alarm will be displayed.
LOW TMR	Low Pressure Timer	30	0	3599s(59m:59s)	second	Low pressure timer. This delay timer needs to be long enough to allow the pump to pressurize the system on start up. It can be used to detect a broken discharge pipe or significant leak. Value is in Seconds (s).
OVERLOAD	S.F.A Setting	12.0	4.0	17.0	Amps	Set to the motor Service Factor Amps (SFA) value as listed on the motor nameplate. The pump will stop if it is pulling excessive amps and the "OVERLOAD" alarm will be displayed. The controller will reset the fault automatically after a cooling period. The controller will reset this fault 4 times automatically before requiring a manual reset.
DRY RUN	Dry Run Amps	0.0	0.0	17.0	Amps	Pump DRY RUN protection. Set this value lower than the normal pump operating amps. 30% lower than the motor Service Factor Amps is common. Adjust up or down as this function is tested. Example: Motor SFA = 10.0A. Set the Dry Run Amps = 7.0A. Set to "0.0" to disable this function (Default)
DRY TMR	Dry Run Timer	30	0	3599s(59m:59s)	Seconds	Time delay before stopping the pump on "DRY RUN" as the amps are lower than the "DRY RUN" Amps value. Timer value is in seconds (s).
RECHARGE	Recharge Timer	20	0	3599m(59h:59m)	Minutes	Automatic reset timer after a "DRY RUN" trip, allowing for enough time for the well to recharge. Timer value is in minutes (m). Set to "0" to disable.
STRT/MIN	Starts Per Minute	2	1	10	Cycles	Rapid cycle protection. Enter the maximum allowable pump starts per minute. If the number of starts is exceed, the display will show "RPD CYCL" and a manual reset is required for the pump to start again.
MAX RUN	Max Run Time per cycle	0	0	3599m(59h:59m)	Minutes	Set the maximum cycle time. The pump will stop and the a "MAX RUN" alarm will be displayed if the cycle time is greater than this value. Set to "0" to disable (default)
NO AMPS	No Amps detect	ON	ON	ON, OFF	NA	The No amps detection function informs the user of thermal switch trip internal to the motor. Allow the motor to cool and it will start again automatically. This detection function is disabled when set to "OFF".
FILTER	Filter Life Timer	OFF	0	9999	hours	Set the estimated pump run time between filter replacements. The time is set in hours (h) and corresponds to pump running hours. A flashing wrench will appear on the screen when this timer is done. This function is disabled by default.

CAUTION: The DY RUN protection is disabled by default. It must be set according to your pump HP and normal running Amps during start up.

ALARM	Fault	Pump	Auxiliary	Auto/Manual Reset	Description	Action
LOW PRES	LOW PRESSURE ALARM	STOP	CLOSED	Auto reset when PSI is back to normal	LOW PRESSURE ALARM Pressure below the Low Pressure set point for longer than the Low Pressure Timer.	Check for leaks, broken pipes. Check the pump and motor.
HIGH PRES	HIGH PRESSURE ALARM	STOP	CLOSED	Auto reset when PSI is back to normal	HIGH PRESSURE ALARM Pressure greater than the High Pressure set point.	Check pump, piping and pressure tank.
DRY RUN	PUMP RUNNING DRY	STOP	CLOSED	Manual reset or reset by recharge if not disabled	PUMP DRY RUN ALARM Pump DRY RUN protection. Set this value lower than the normal pump operating amps. 30% lower than the motor Service Factor Amps is common. Example: Motor SFA = 10.0A. Set the Dry Run Amps = 7.0A. Set to "0.0" to disable this function (Default).	If the pump is tripping on DRY RUN but there is water in the well, decrease this setting. If the pump is NOT tripping on DRY RUN, then increase this value.
RAPID CYCLE	PUMP RAPID CYCLING	STOP	CLOSED	Manual reset	RAPID CYCLING ALARM This is the maximum allowable pump starts per minute. If the number of cycles per minute is exceeded, the pump will not start and the RDP CYCL alarm will be displayed.	Check the pressure tank for damage or incorrect pre-charge pressure. These commonly result in the pump rapid cycling. Correct or replace pressure tank. Increase the number starts per minute for systems with small pressure tanks. Contact the pump/motor manufacturer for the max allowable starts/minutes.
MAX RUN	MAXIMUM RUN TIME	STOP	CLOSED	Manual reset	MAXIMUM RUN TIME ALARM Maximum runtime allowed in one cycle.	Check for pipe leaks or faucet left open. Increase time if necessary
NO AMPS	NO AMPS DETECTED	NONE	CLOSED	Auto reset	NO AMPS DETECTED No amps are detected which implies that the thermal switch internal to the motor has tripped or that the pump is not connected. When the "NO AMPS" function is enabled, it will ignore the Low Pressure and Dry Run conditions and maintained the RUN command to the pump until the motor has cooled down and restarts automatically.	If it is a motor thermal trip, then allow the motor to cool and it will start again automatically. Investigate the cause of the motor internal trip. If the motor is not connected, check the motor wiring. The NO AMPS function can be disabled when set to "OFF".
OVERLOAD	MOTOR OVERLOAD	STOP	CLOSED	Auto reset / Manual reset	Class10 overload protection, calculated based on the motor S.F.A. load. The overload will automatically reset after a cooling period. It must be manually reset after four consecutive times trips.	Check the pump for clogging or locked rotor condition.
WATER SW	WATER SWITCH ACTIVE	STOP	CLOSED	Auto reset	Digital input from the optional floor sensor or float switch. If the input of water sensor is ON for more than 5 sec, shut down the pump and display "WATER SW". This alarm will auto reset when the switch opens.	Check the water sensor or float switch. Correct the cause of water leakage or water supply prior to resetting the fault.
XDR OPEN	TRANSDUCER OPEN	STOP	CLOSED	Auto reset	PRESSURE TRANSDUCER OPEN CONNECTION Active when the 4-20mA signal input value is < 3.0mA	Check the transducer cable connection to the pressure sensor. Make sure it is connected properly and hand tightened. Check the transducer cable for damage. Replace cable if damaged. Check the transducer cable connections to the controller. Make sure there is a good connection.
XDR SHORT	TRANSDUCER SHORT	STOP	CLOSED	Auto reset	PRESSURE TRANSDUCER SHORT CIRCUIT Active when the 4-20mA signal input value is > 21mA	Same as above. In addition, check the pressure transducer. Remove it and inspect for damage. Replace if it is damaged.
RECHARGE	WELL IS RECHARGING	STOP	CLOSED	Hold ESC for 4 sec if you want to cancel the timer and re-start the pump immediately	WELL IS RECHARGING - PLEASE STAND BY This is the waiting time after the pump as tripped on "Dry Run" fault, before performing an automatic reset.	Wait for the recharge timer to complete. Increase or decrease this timer value as needed to match the recovery time of your well.
CHNG FILTER	CHANGE FILTER	NONE	NONE	Hold ESC for 4 sec to reset the filter capacity to 100%	CHNG FILTER & Wrench Icon is displayed for 2 second every 7 seconds when the pump has run for the time listed in the users filter setting.	Replace or clean the filter regularly to keep the pumping system running at optimal efficiency.

Start Circuitry Overload Protector (For 2HP & 3HP only)

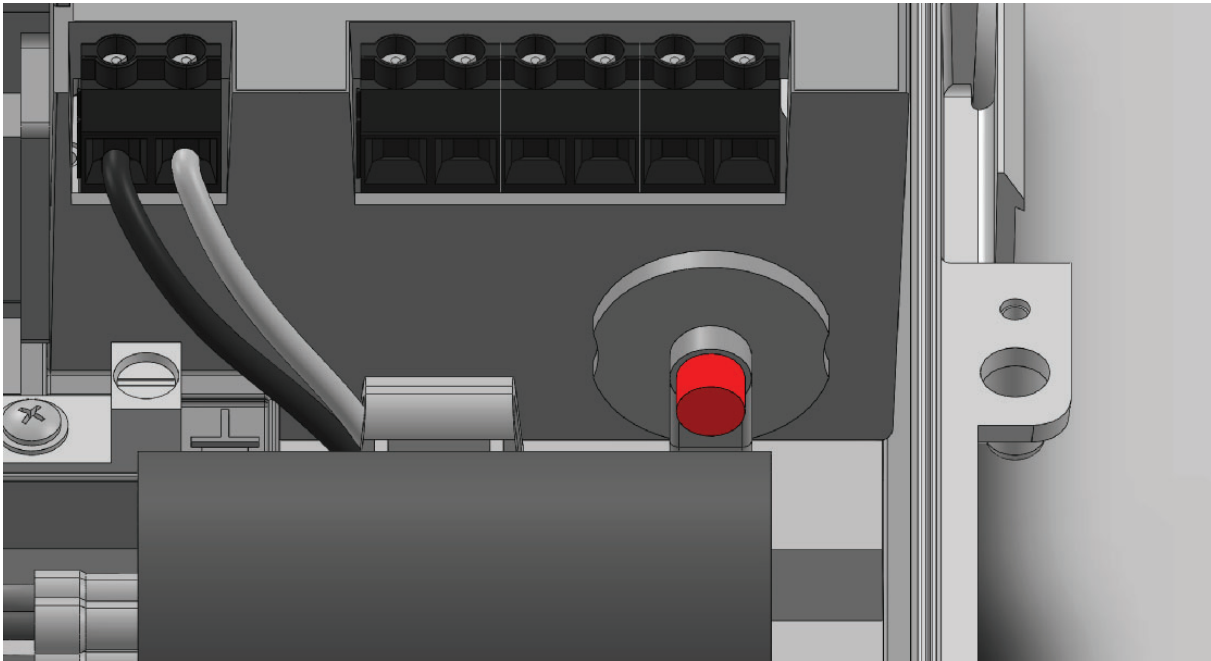

There is an additional overload (OL) protection device on 2HP and 3HP control panels. This OL device is for the protection of the START Circuitry and is located below the terminal blocks. Press the red button to reset.

Q: What are symptoms when the start overload is tripped?

A: There is a short in the start circuitry or a locked rotor situation. The pump will not start when this overload protector has tripped. Press the red button to reset. The digital display may also display "OVERLOAD" and must be reset (Press ESC button for 4 sec).

Q: How to check the circuit with a multimeter?

A: If the pump does not start after a reset. To verify that OL has reset, measure the resistance (ohm) from T1 and the black wires in the cap kit. It should measure continuity (<10 ohms). Check the start relay and capacitors as well.

Q: How to reset?

A: To reset, wait at least 10 minutes after the trip to allow for the unit to cool down and press the red button.

Q: What do you do if the start overload keeps tripping?

A: Check the capacitors and start relay. Check the motor if locked. Check ambient temperature in the control panel. The overload module will trip sooner if hot. Protect the control panel from direct sunlight.

REPLACEMENT PART NUMBERS

Part#	1094602	1094603	1094604	1094605	1094606	1094638
	WellZone 3W-050	WellZone 3W-075	WellZone 3W-100	WellZone 3W- 150	WellZone 3W-200	WellZone 3W-300
HP	1/2	3/4	1	1 1/2	2	3
SFA	4.3	5.7	7.1	11.5	13.2	17.0
Volts	230	230	230	230	230	230
RUN CAP	15mF	23mF	23mF	15mF	20mF	45mF
Part#	1036323	1004023	1004023	1036323	1003706	1003829
Mars	12210	12215	12215	12210	12214	12223
	370V	370V	370V	370V	370V	370V
START CAP	43-56mF	59-71mF	88-108mF	108-130mF	108-130mF	216- 59mF
Part#	1098476	1098478	6001275	1027120	1027120	1002979
Volt	250	250	250	250	250	250
Mars	11942	11943	11945	11946	11946	11952
Start Relay	HLR3800- 2AL3D	HLR3800- 2AL3D	HR3800- 2AL3D	HR3800- 2AL3D	HR3800- 2AL3D	HR3800- 2AL3D
Part#	1098479	1098479	1098479	1098479	1098479	1098479
Start OL				GA3VPA7421	GA3VRA0021	
Par#				1104244	1104245	
CB	15A	20A	20A	20A	25A	30A



**Technical support,
service questions:**

+1-800-746-6287
techsupport@sjeinc.com

Monday - Friday
7:00 AM to 6:00 PM Central Time