

FEATURES

Convertible: May be used on shallow or deep well applications using appropriate Goulds Water Technology fittings.

Serviceable:

- Back pullout design for service without disturbing piping.
- Two compartment motor for access to wiring and replaceable components.
- Nozzle clean out plug in shallow well adapter.
- Corrosion resistant, plastic tubing and fittings are easily removed for cleaning. Premium O-ring design fittings need only be hand tight to seal.

Impeller: F.D.A. compliant, glass filled Noryl®. Corrosion and abrasion resistant.

Diffuser (Guidevane): Bolt down Lexan® diffuser has stainless wear ring for extended performance in abrasive conditions.

Powered for Continuous Operation: Pump ratings are within the motor manufacturer's recommended working limits. Can be operated continuously without damage.

Corrosion Resistant: Electro-coat paint is baked on.

Protected Mechanical Seal: Diaphragm retains water in the casing to ensure the mechanical seal can never run dry.

Excellent Air Handling Ability: After initial priming the pump has the ability to re-prime itself.

AGENCY LISTINGS



Canadian Standards
Association



Underwriters
Laboratories®



J+

J5, J7, J10 AND J15

CONVERTIBLE JET PUMPS ½, ¾, 1 AND 1½ HP - 60 HZ

APPLICATIONS

Specifically designed for:

- Homes
- Farms
- Cottages
- Booster service

SPECIFICATIONS

Pump:

- Pipe connections: 1 1/4" NPT suction, 1" NPT discharge, 1" NPT drive (pressure)
- Pressure switch: AS4 preset at 30-50 PSI

Motor:

- NEMA standard
- 60 Hz
- 1/2 – 1 1/2 HP, 115/230 V capacitor start
- Single phase
- 3500 RPM
- Built-in overload with automatic reset
- Stainless steel shaft
- Rotation: clockwise when viewed from motor end
- UL778 listed

Maximum temperature: 140°F

SYSTEM COMPONENTS

- **Basic Pump Unit:** Includes pump and motor, pressure gauge and bushing, pressure switch with tubing and fittings.

NOTE: THE TUBING COMES CONNECTED FOR SHALLOW WELL USE. A DEEP WELL SET UP REQUIRES A JDW FITTINGS PACKAGE OR AN AV22 KIT.

Both include additional fittings and a 24" tubing to connect to a pressure control valve.

ADDITIONAL COMPONENTS REQUIRED

- **Shallow Well Package:** Includes shallow well adapter, nozzle, venturi (diffuser), gasket, bolts and pipe plugs OR
- **Deep Well Package:** Choose either a twin pipe or packer style.
 - Twin pipe includes jet body, nozzle, venturi (diffuser) and foot valve.
 - Packer includes packer body, nozzle, venturi (diffuser), and built-in check valve.

NOTE: Packer systems also require a packer adapter on the wellhead.

Deep well systems require a pressure control valve.

NOTE: YOU MUST HAVE A JDW OR AV22 KIT TO MAKE THE PRESSURE SWITCH CONNECTION.

Pressure tank required on all systems.

MODEL INFORMATION

CSA Listed Order No.	U.L. Listed (Indoor use)① Order No.	HP
J5	J5UL	1/2
J7	J7UL	3/4
J10	J10NUL	1
J15	J15UL	1 1/2

SHALLOW WELL PERFORMANCE RATINGS

HP/Model	1/2 HP – J5					1/2 HP – J5					3/4 HP – J7					1 HP – J10					1 1/2 HP – J15					
Shallow Well Package	FH5					FH5H (High Pressure Model)					FH7					FH10					FH15					
Adapter	4K62																									
Nozzle	AN017					AN019					AN018					AN018					AN022					
Venturi	AD3731					AD3528					AD3536					AD3538					AD3542					
Total Suction Lift (feet)	Discharge Pressure – PSI					Discharge Pressure – PSI					Discharge Pressure – PSI					Discharge Pressure – PSI					Discharge Pressure – PSI					
	20	30	40	50	Max. Shut off (PSI)	20	30	40	50	60	Max. Shut off (PSI)	30	40	50	60	Max. Shut off (PSI)	30	40	50	60	Max. Shut off (PSI)	30	40	50	60	Max. Shut off (PSI)
	Gallons per minute					Gallons per minute					Gallons per minute					Gallons per minute					Gallons per minute					
5	17.5	16.5	10.2	5.0	63	11.5	11.3	11.0	7.7	4.8	83	21.3	18.3	12.5	6.6	70	24.8	24.4	16.6	9.9	74	26.6	26.3	25.0	15.6	80
10	15.7	14.4	9.2	4.3	61	10.3	10.0	9.6	7.0	4.2	81	18.8	17.3	11.3	5.0	68	22.9	22.2	15.8	8.6	72	24.7	24.3	22.6	13.9	77
15	13.7	12.5	8.0	3.6	59	8.8	8.6	8.3	6.3	3.7	79	16.4	15.5	9.6	3.7	66	19.8	19.5	13.8	6.9	70	21.6	21.5	20.4	12.9	75
20	11.5	10.4	7.1	2.3	57	7.0	7.0	6.8	5.8	3.2	76	13.6	13.2	8.3	2.0	63	16.6	16.6	12.2	5.6	67	18.1	18.0	17.6	12.0	73
25	8.7	8.6	6.2	1.3	54	5.3	5.2	5.2	5.0	2.8	73	10.0	9.9	6.4	1.0	59	12.5	12.4	10.4	3.6	65	14.0	14.0	14.0	10.1	71

TWIN PIPE PERFORMANCE RATINGS

HP/Model	½ HP – J5				¾ HP – J7				1 HP – J10				1½ HP – J15				
Well Casing min. I.D.	4		4½		4		4½		4		4½		4½				
Pressure	1		1¼		1		1¼		1		1¼		1¼				
Suction Pipe Size (in.)	1¼		1½		1¼		1½		1¼		1½		1½				
① Jet Assembly Package	FT4-13	FT4-31	FT4-08	FT5-14	FT4-14	FT4-34	FT4-18	FT5-47	FT5-48	FT4-44	FT4-43	FT4-18	FT5-49	FT5-11	FT5-12	FT5-11	
Jet Body (only)	AT4			AT5		AT4			AT5		AT4			AT5		AT5	
Nozzle	AN017	AN016	AN015	AN018	AN017	AN016	AN016	AN018	AN017	AN017	AN017	AN016	AN019	AN018	AN019	AN018	
Venturi	AD726	AD723	AD720	AD724	AD729	AD725	AD722	AD730	AD725	AD730	AD727	AD722	AD732	AD727	AD734	AD727	
② Control Valve Setting (PSI)	30	30	30	30	28	29	30	28	30	31	33	35	30	32	35	40	
Feet	Gallons Per Minute (GPM) 30-50 PSI Pressure Switch Setting																
Depth to Jet Assembly (based on submergence of 5 feet)	30	13.0	11.0			15.8			16.6		17.0			19.3		21.2	
	40	11.8	9.0			15.7			16.0		16.6			18.0		20.0	
	50		7.6		6.9	13.2			15.0		14.4			16.0		16.1	
	60		7.0	5.2	6.4	10.2			13.0		11.5	11.2		14.3		15.0	
	70			4.7	5.6		8.2		11.0	10.0		9.3		12.6		14.0	11.2
	80			3.8	4.8		6.5		8.6		7.3	6.2	10.0	10.0			10.6
	90			3.1	4.1		5.0	5.0	7.3			6.1		8.7			9.0
	100							4.4	6.0			5.4		7.0			7.6
	110							3.5	5.0			4.5		5.7			6.2
	120													4.5			5.2
	130																4.0
	140																2.8
	150																1.5
	160																
170																	

NOTE: An offset of 50 feet will result in a decrease of about 25% from ratings as shown.

- ① Jet assembly package includes jet body (AT4), venturi, nozzle and foot valve.
- ② Deep well jet pumps require a pressure control device on the discharge to provide back pressure to the jet assembly. Failure to control the amount of discharge by adjusting the back pressure (pressure control valve setting) will cause the pump to lose prime. On pumps with low control valve settings, up to 40 psi, a simple ball valve or AV15 will work. On systems with control valve settings of 40 - 80 psi an AV22, AV22KIT or AV21 is required. They measure the pressure on the outbound side so that the high pressure does not open the 30-50 psi switch and turn the pump off.

PACKER SYSTEM PERFORMANCE RATINGS

HP/Model	½ HP – J5				¾ HP – J7				1 HP – J10				1½ HP – J15					
Well Casing	2		3		2		3		2		3		3					
Suction Pipe Size (in.)	1¼		1½		1¼		1½		1¼		1½		1½					
Jet Assembly Package ①	FP2-13	FP2-31	FP2-08	FP3-36	FP3-24	FP2-40	FP2-47	FP3-53	FP3-54	FP2-48	FP2-43	FP3-55	FP3-14	FP3-16	FP3-18	FP3-21	FP3-24	
Jet Body (only)	AP2			AP3		AP2		AP3		AP2		AP3		AP3				
Nozzle	AN017	AN016	AN015	AN021	AN018	AN015	AN015	AN018	AN017	AN016	AN016	AN019	AN018	AN019	AN021	AN023	AN018	
Venturi	AD726	AD723	AD720	AD730	AD724	AD727	AD723	AD730	AD725	AD729	AD725	AD732	AD727	AD735	AD723	AD731	AD724	
Control Valve Setting (PSI) ②	30	30	30	30	30	30	32	27	30	35	36	28	32	34	34	34	39	
Feet	Gallons Per Minute (GPM) 30-50 PSI Pressure Switch Setting																	
Depth to Jet Assembly (based on submergence of 5 feet)	30	11.9	9.5		13.1			13.8		16.8		16.7		19.3				
	40	10.6	7.9		12.6			13.5		16.8		14.6		19.3		23.1		
	50		7.6		10.7	6.9		11.5		15.3		13.5		18.0		20.2		
	60		6.7	4.8	8.8	6.5	9.0	7.8	13.5		11.0	9.2	15.3		16.9	15.0		
	70			4.3	7.3	5.6		7.1	11.5	9.8		9.0	12.7			14.4		
	80			3.5		4.8		5.1		8.6		7.3	10.2	10.3		12.9		
	90							4.3		7.3		5.6		8.8		10.9	10.3	
	100									6.2		4.2		7.2			9.6	7.3
	110									5.0				5.8			8.2	6.5
	120													4.5			6.9	5.8
	130																5.8	5.0
	140																4.7	4.5
	150																3.4	4.0
	160																	3.3
170																	2.8	

NOTE: An offset of 50 feet will result in a decrease of about 25% from ratings as shown. Special turned (diameter) couplings are required on 2" packer systems, order no. 64655 in Jet and Sub price book.

- ① Jet Assembly Package includes jet body, AP2 or AP3; built-in check valve, nozzle and venturi.

- ② Same as above

COMPONENTS

Item No.	Description
1	Mechanical seal
2	Pressure switch
3	Casing
4	Impeller
5	Diffuser (Guidevane)
6	Diaphragm
7	Stainless steel shaft
8	Nozzle clean-out plug
9	Motor adapter
10	Motor
11	Nozzle
12	Venturi

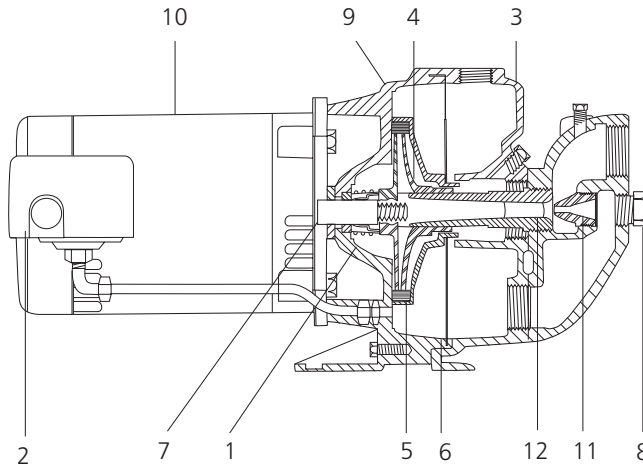

Shallow Well Model

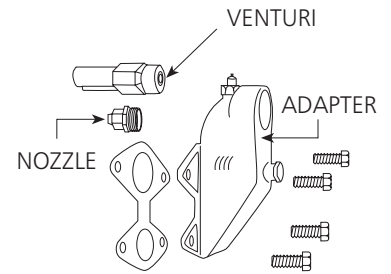

Shallow Well Package

DIMENSIONS AND WEIGHTS

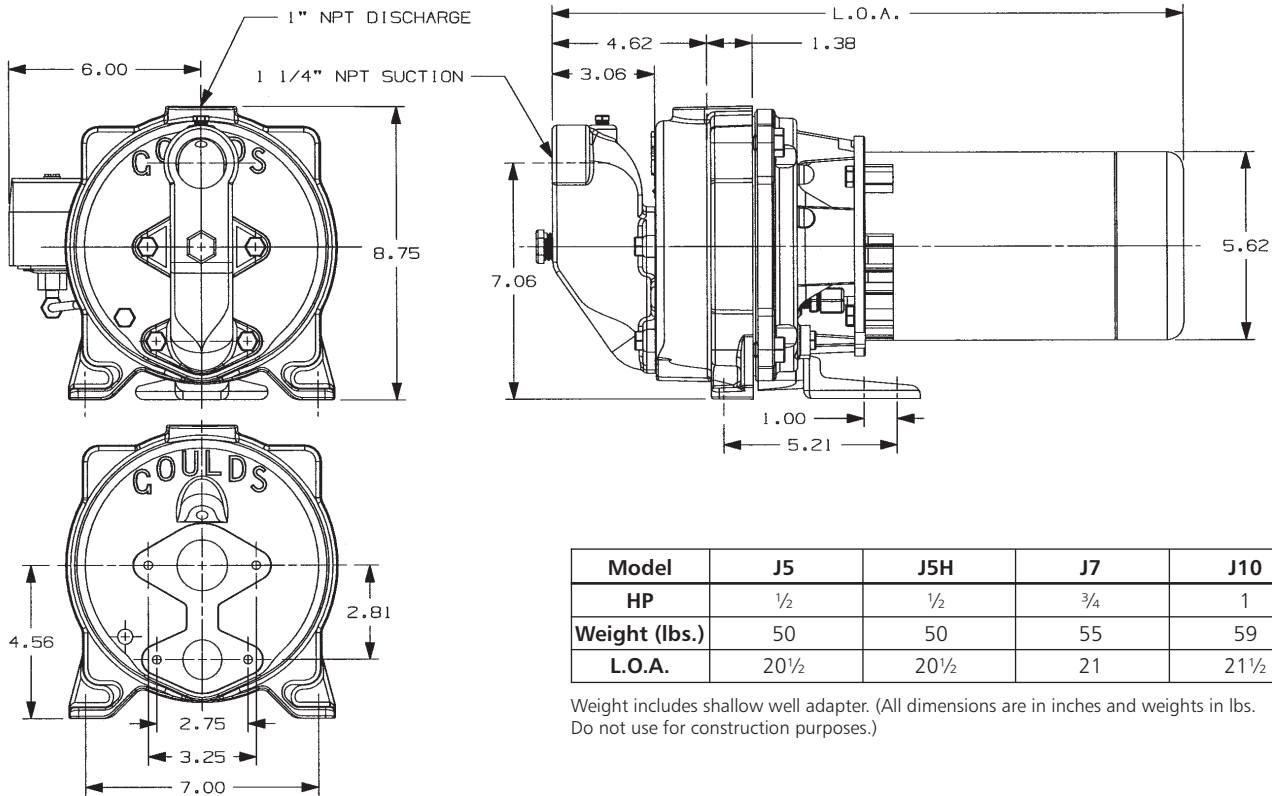

Model	J5	J5H	J7	J10	J15
HP	1/2	1/2	3/4	1	1 1/2
Weight (lbs.)	50	50	55	59	68
L.O.A.	20 1/2	20 1/2	21	21 1/2	24

Weight includes shallow well adapter. (All dimensions are in inches and weights in lbs. Do not use for construction purposes.)

xylem
Let's Solve Water

Xylem, Inc.
2881 East Bayard Street Ext., Suite A
Seneca Falls, NY 13148
Phone: (866) 325-4210
Fax: (888) 322-5877
www.xylem.com/brands/gouldswatertechnology

Goolds is a registered trademark of Goolds Pumps, Inc. and is used under license.
Noryl and Lexan are trademarks of GE Plastic.
© 2012 Xylem Inc. BJ+ January 2012